

ROHS

NOTES:

- Voltage Rating: 100V, AC/DC
- Current Rating: 1.0 AMP, AC/DC
- Dielectric Withstand Voltage: 500V, AC/Minute
- Contact Resistance: 20 mΩ Max
- Insulation Resistance: 1000 mΩ Min
- Operation Temperature: -40°C to +105°C
- Insulator Material: Polyester, UL94 V-0
- Contact Material: Brass
- Contact Plating: Au Plated on Nickel Overall

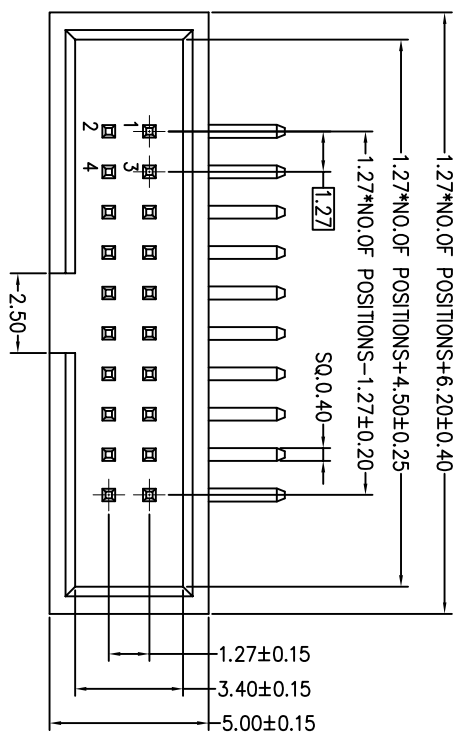

Dimension antitheses list	
Item	PA
Standard	2.4
Alternate	---

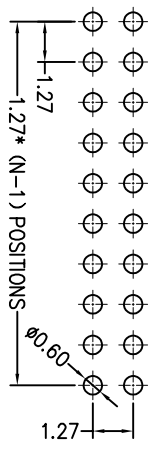

Recommended P.C.B Layout
P.C.B Board Tolerance±0.05

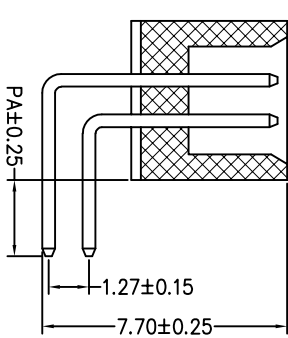
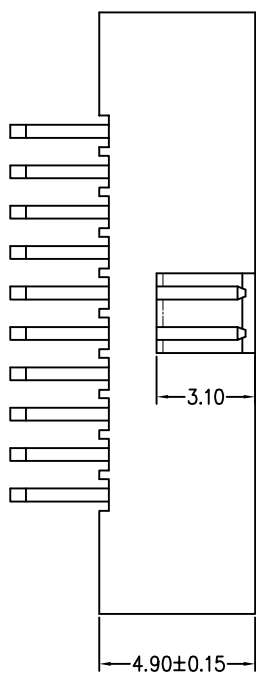

SHINHWA TECH CO., LTD

PART NUMBER

BHA9-XX-G1

TITLE

1.27 BOX HEADER RA H: 4.9

版本 (REV)	A/0	X.XX	X.XX	X.XX	0.10	0.30	0.20	0.10	MM	FREE	2021.05.12	审核 (APPROVE)
单位 (UNIT)	MM	绘图 (DRAWN BY)	pingquan	比例 (SCALE)	FREE	核对 (CHECKED BY)	陈 R	日期 (DATE)	2021.05.12	核准 (APPROVE)		

A

B

C

D

E

F

G

5

4

3

2

1

5

4

3

2

1